

Pre-Junior Certificate Examination, 2013

Technical Graphics

Ordinary Level

Section B

(280 marks)

Time : 2½ Hours

Instructions

- (a) Answer **any four** questions. All questions carry equal marks.*
- (b) The number of the question must be distinctly marked by the side of each answer.*
- (c) Work on **one side** of the answer paper only.*
- (d) Write your name, your school's name and your teacher's name on each sheet of paper used.*

SECTION B. Answer **any four** questions. All questions carry equal marks.

1 The figure shows a design for a pencil sharpener. A 3D graphic of the pencil sharpener is also shown.

Draw:

- (a) An elevation in the direction of arrow **A**.
- (b) An end elevation in the direction of arrow **B**.
- (c) Insert **any four** dimensions.

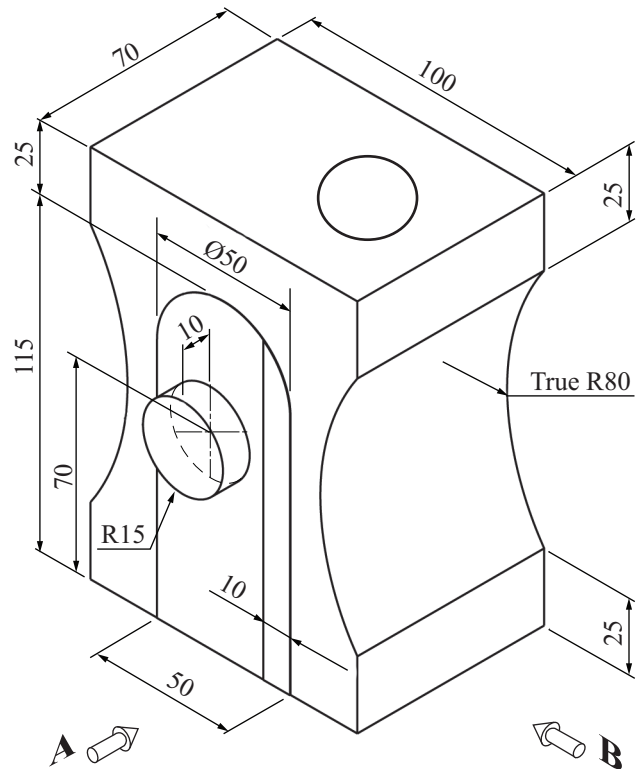

2 The figure shows the design of a logo for a canoe club.

The curve **ABCD** is an ellipse. **AC** is the **major axis** and is 180 mm long.

BD is the **minor axis** and is 100 mm long as shown.

EFG is an arc of a circle.

Draw the given logo showing clearly all construction lines.

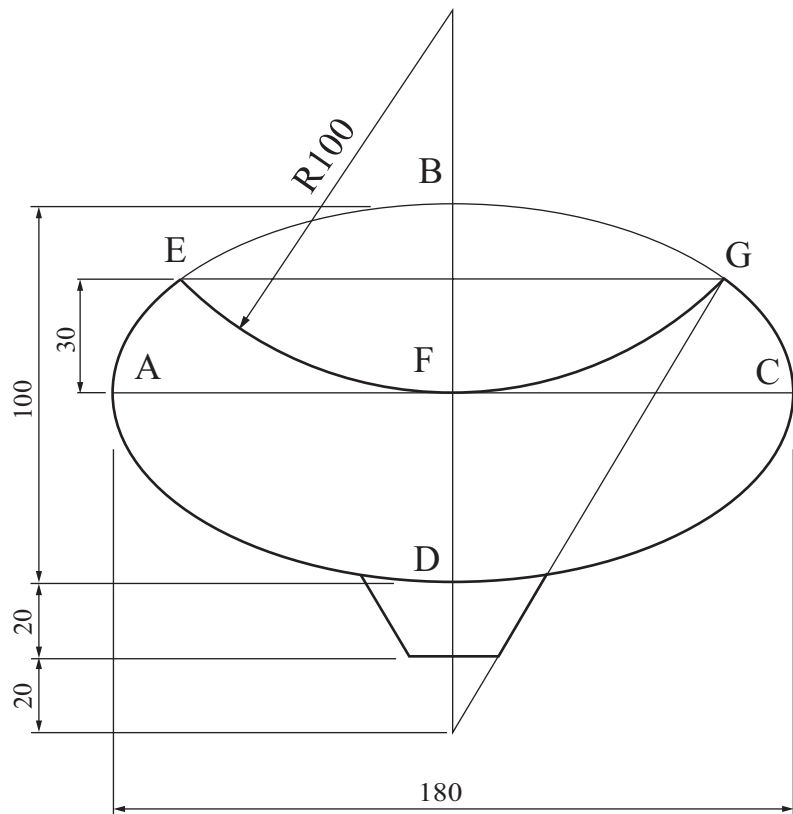

3 The figure shows a design for a desk tidy.

Draw:

- (a) An elevation in the direction of arrow A.
- (b) An end elevation projected from the elevation.
- (c) The complete **surface development** of the desk tidy.

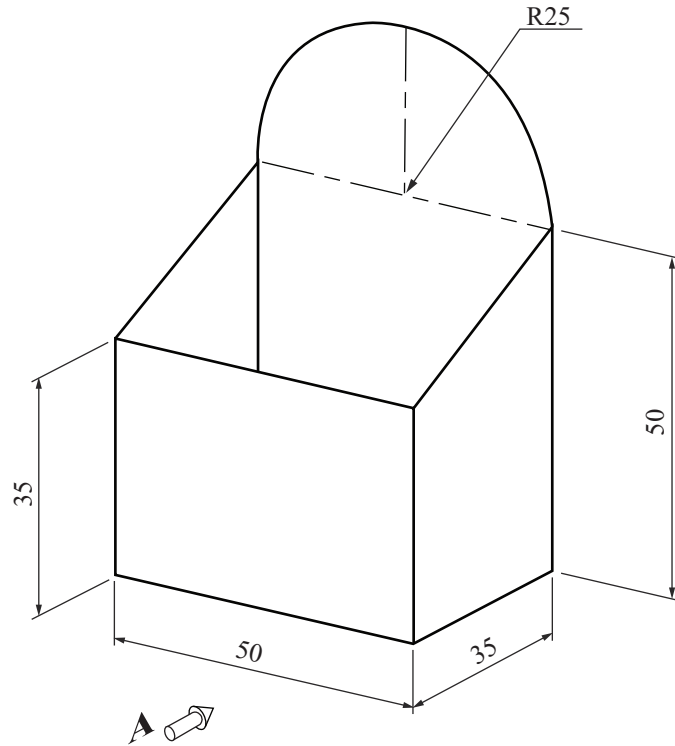

4

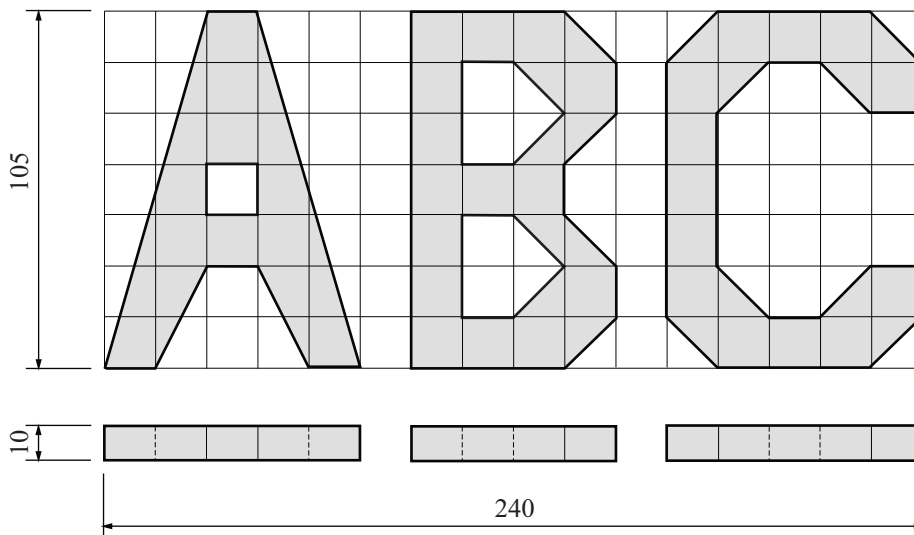

The figure shows the elevation and plan of the initials **ABC**.

The grid in elevation is made up of 15 mm squares and the thickness in plan is 10 mm.

Draw **one** of the following views:

- (a) An **isometric** view of the letters

or

- (b) An **oblique** view of the letters.

Note: The solution must be presented on standard drawing paper.

5

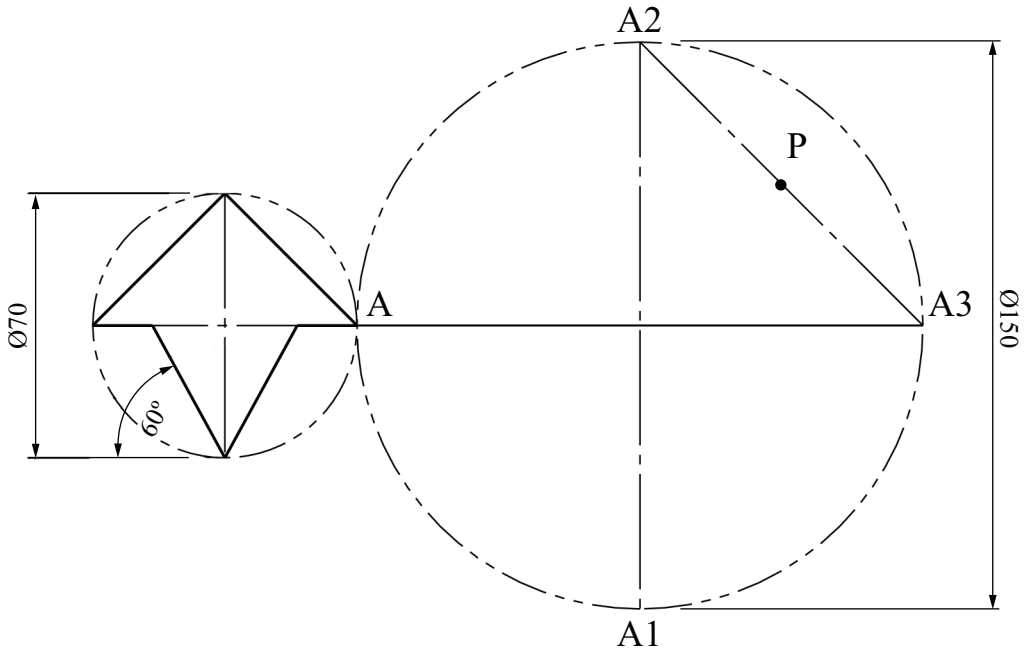

The given figure shows the design of a logo for a hat shop.
 Draw the given logo and then locate the points **A**, **A1**, **A2**, **A3**, **P** and the line **A-A3** as shown.

Find the image of the given figure under the following transformations:

- (a) From point **A** to **A1** by a **translation**;
- (b) From point **A1** to **A2** by an **axial symmetry** in the line **A-A3**;
- (c) From point **A2** to **A3** by a **central symmetry** in the point **P**.

6 The figure shows the outline of a hammer.

Reproduce the given figure showing clearly how to find the centre points for all the circles.

Show all construction lines, tangents and points of contact.

